

SPECIAL EDITION MIDNIGHT V3 WHALE TAIL HANDLE KIT

FEATURES

- New modern design
- Adjustable nylon roller cam - grip range: (H=) 20mm-40mm
- Heavy-duty stainless steel main shaft
- Die cast dish and handle
- Cast-in high tensile fixing studs
- Suitable for single or multi-point locking
- Ergonomic and secure handle with purpose designed "deboss" to allow location for builder's branding decal/badge
- Right-handed orientation central locking actuator
- High-security Euro profile key cylinder
- High-security half Euro barrel has inbuilt drill protection
- Padlockable hasp for additional security
- Commonly used cutout template
- IP65

DIMENSIONS

Height: 140mm

Width: 140mm

MATERIAL & FINISH

Bracket: Zinc die, zinc plated

Cam & Shaft: Mild steel, zinc plated

Dish & Handle Finish:

Polished chrome plating

KIT INCLUDES

*Includes all parts & qty's listed below

- Special Edition Midnight V3 Handle (Chrome) - x1
- Right-handed orientation central locking actuator and mounting bracket - x1
- High-security Euro profile cylinder - x1
- Quick release locking rod posts with circlips - x2

ACCESSORIES (SOLD SEPARATELY)

Connector Clips & Roller Attachments:

- ROD###E *Locking rods with eyelets
- RG007 * Roller Attachment for ROD###E
- RG008 *Nylon Connector Clip

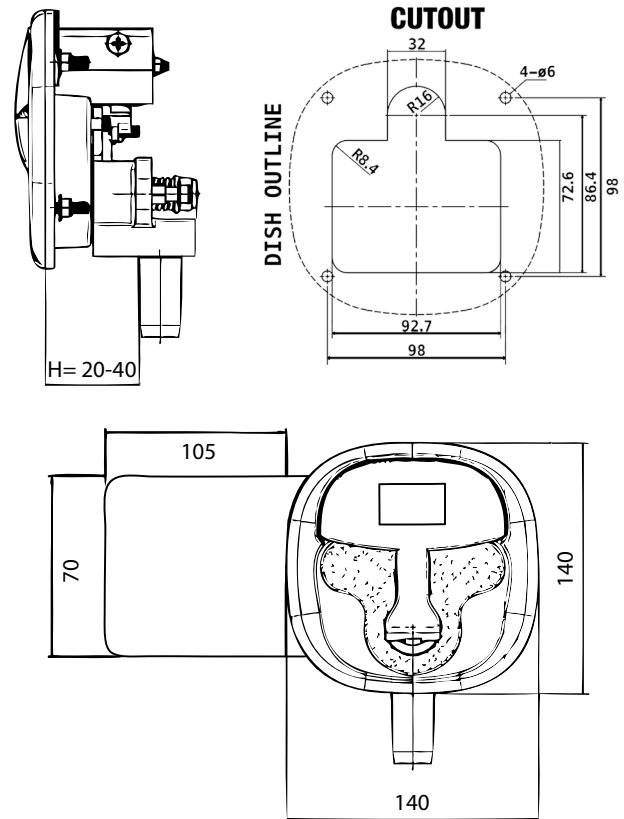

*Technical drawings are a visual reference aid only and may differ slightly to the physical product.

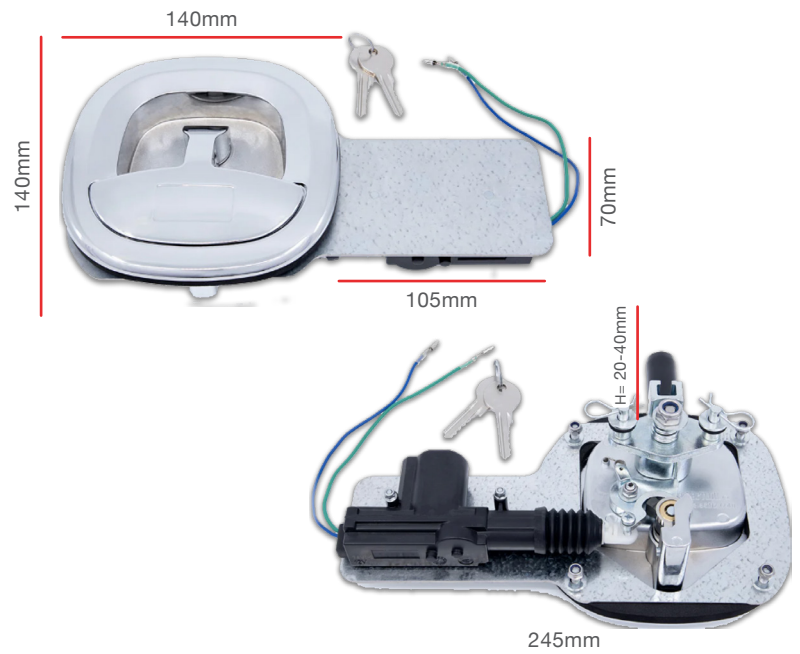

HANDLE & DISH	CAM VARIANT	KEY NUMBER	PART NUMBER
Polished Chrome Plating	Nylon Roller Cam	Half Euro Profile	P1086-01-KIT-R

Patent/design registration applied for

PLEASE NOTE:

Available only while stock lasts | Pickup available in Tullamarine | Shipping Australia-wide | Unless specifically requested - multiple handles in one order will all be keyed the same | Only available with right-handed orientation central locking actuators | Central locking kit includes; screws, washers, actuator and mounting bracket