

SELF ADHESIVE TAPE

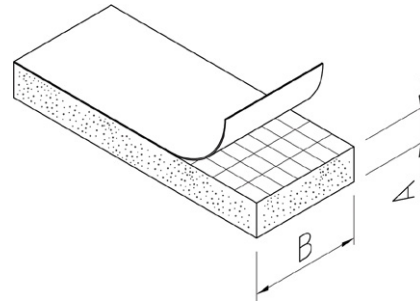

FEATURES:

- Scrim netting for better resistance to overstretching
- High quality adhesive
- Supplied in 10m rolls
- Other sizes available
- Closed cell construction

MATERIAL:

EPDM

TECHNICAL PROPERTIES	TEST METHOD	VALUE
Cellular Structure	-	Closed
Colour	-	Black
Density (kg/m ³)	ISO 845-88	130
Water Absorption (%)	ASTM D 1056	<8
Temperature Range Constant (°C)	ASTM D 3575	-40 / +80
Temperature Range Intermittent (°C)	-	-
Linear Shrinkage (%)	After 22H 70 °C	Max -5
Ultimate Elongation	ASTM D 412	>150
Tensile Strength (kpa)	ASTM D 412	400
Tear Resistance (kN/m)	ASTM D 624	0.5
Air + UV Resistance	Exellent	
Ozone Resistance	168 h/200pphm	
Compression Strength (kpa)	ASTM 1056-85	%25' de => 35
Compression Set (%)	ASTM D 395 (%50-22H)	5
Shore Hardness (Shore C)	ASTM D 2240	35 ±5
Fire Resistance	-	-
Peroxide Cure	-	-
Specification	-	-

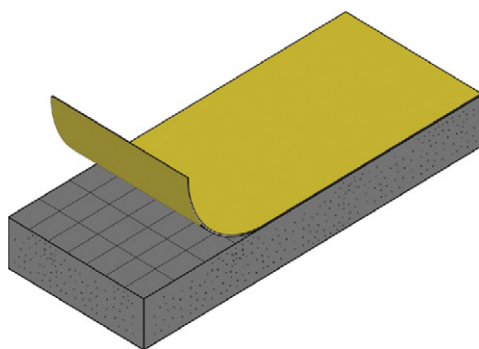

"A" (mm)	"B" (mm)	MATERIAL	PART NUMBER
3	20	EPDM	M1200-3-20
5	10	EPDM	M1200-5-10
5	25	EPDM	M1200-5-25
5	20	EPDM	M1200-5-20
5	30	EPDM	M1200-5-30
3	12	EPDM	EPDMFT12X3
3	24	EPDM	EPDMFT24X3
4.5	9	EPDM	EPDMFT9X4.5
4.5	18	EPDM	EPDMFT18X4.5
6	24	EPDM	EPDMFT24X6
9	24	EPDM	EPDMFT24X9
9	48	EPDM	EPDMFT48X9
12	18	EPDM	EPDMFT18X12